

GENUINE ALUMINUM ACCELERATOR PEDAL KIT

INSTALLATION AND USER'S INSTRUCTIONS



Thank you for purchasing a genuine Mazda accessory.

Before removal and installation, be sure to thoroughly read these instructions.

Please read the contents of this booklet in order to properly install and use the aluminum pedal kit. Your safety depends on it.

Keep these instructions with your vehicle records for future reference.

WARNING

- There are several  **WARNING** and  **CAUTION** sections in this booklet concerning safety when installing or removing the aluminum pedal kit. Always read and follow them in order to prevent injuries, accidents, and possible damage to the vehicle.

 **WARNING:** Indicates a situation in which serious injury or death could result if the warning is ignored.

 **CAUTION:** Indicates a situation in which bodily injury or damage to the vehicle could result if the caution is ignored.

- For areas indicating the tightening torque in this instruction manual, tighten to the specified torque using a torque wrench. For areas in which the tightening torque is indicated inside parentheses (), the tightening torque is indicated as a reference value, however tightening using a torque wrench is not necessary.
- Do not modify the aluminum pedal kit.
- Do not install the aluminum pedal kit in any way other than described in the following instructions.
- If in any doubt, please ask your Mazda dealer to install the accessory in order to prevent errors in installation.
- If you have any questions about the use of the accessory, ask your Mazda dealer for proper advice before using it.
- Mazda and its suppliers are not responsible for injuries, accidents, and damage to persons and property that arise from the failure of the dealer or installer to follow these instructions.
- To ensure safety and reliability of the work, installation, removal and disposal work must be carried out by an Authorized Mazda Dealership.
- Be careful not to lose removed parts, and be sure that they are kept free from scratches, grease or other dirt.

PART NAME: Aluminum accelerator pedal kit

PART NUMBER: BHN1 V9 091

BHN2 V9 091

VEHICLE: MAZDA3, MAZDA6, MAZDA CX-5

NOTE

To the dealer

- Please turn over these instructions to the customer after installation.

To the customer



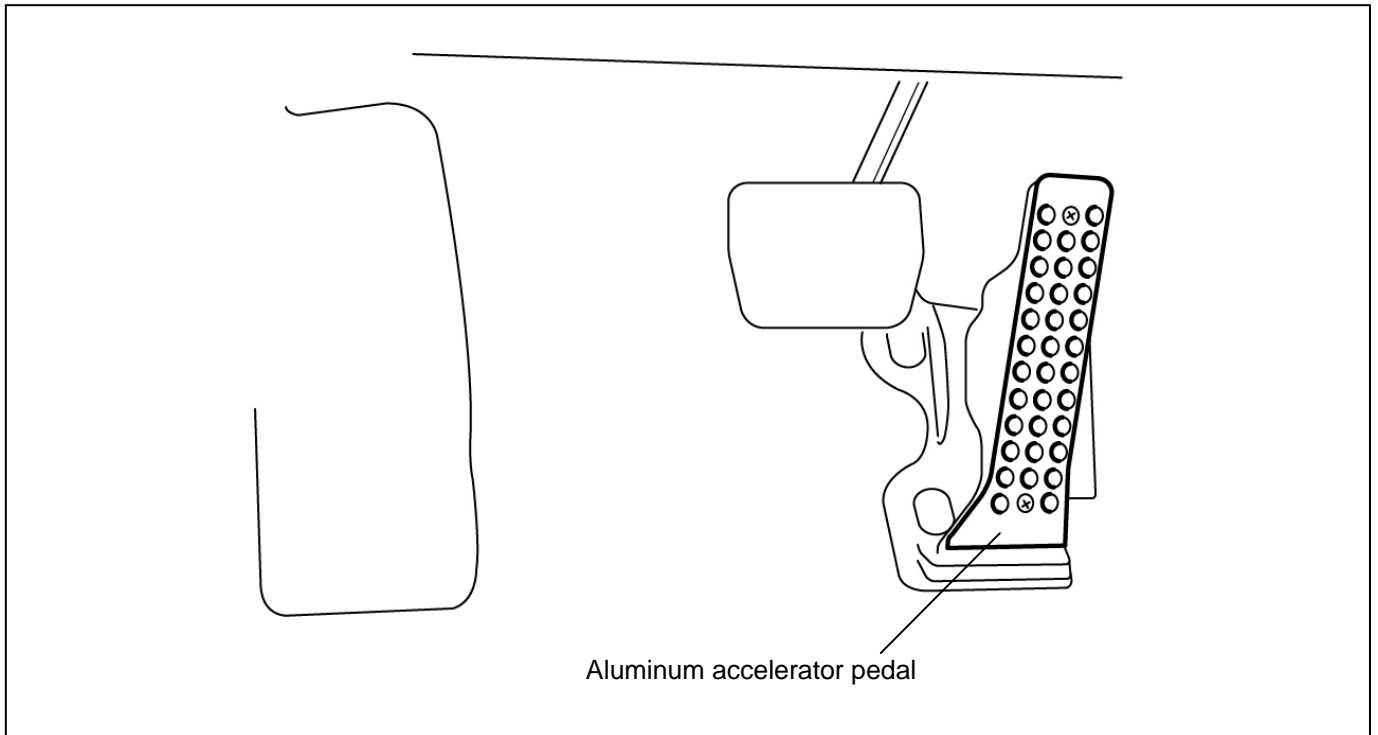

- Keep these instructions after installation. The instructions may be necessary for installing other optional parts or removal of this accessory.
- Should the vehicle or this accessory be resold, always leave these instructions with it for the next owner.

1. INSTALLATION VIEW

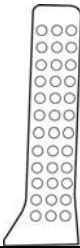

2. PARTS

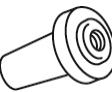
- Before installation, verify that the kit includes all the following parts and that they are free of dirt, scratches, or damage.

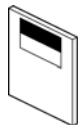
Part	Part name	Qty	Part	Part name	Qty
	Aluminum accelerator pedal pad	1		Template	1
	Well nut	2		Screw	2
	Installation and user's instructions	1			

3. BEFORE INSTALLATION

■ REQUIRED TOOLS

- ☆Screwdriver (Phillips) ☆Trim removal tool ☆Torque wrench ☆Electric drill (2.5 mm, 7 mm drill bits)
- ☆Utility knife ☆Tape ☆Soft clean cloth ☆Loctite (Recommendation product: ThreeBond 1303N)

⚠ WARNING

Before performing any work, park the vehicle on level ground, apply the parking brake securely, and then block the wheels. If the vehicle moves while performing work, it could cause a serious accident.

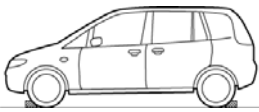

⚠ CAUTION

<p>Be sure to cover the vehicle body with protectors or mats to prevent stains, scratches and damage when removing/installing the vehicle parts</p>	<p>Using improper tools may cause damage and or broken parts. Use the correct tool for the job.</p>	<p>Wrap protective tape around screwdrivers and fastener remover tools to prevent scratching the vehicle.</p>	<p>Put the removed parts and the parts in the kit on the protective sheet to prevent scratches.</p>
<p>Be sure to cover the vehicle body with protectors or mats to prevent stains, scratches and damage when removing/installing the vehicle parts</p>	<p>To prevent scratching the vehicle and over-drilling, wrap the drill bit with duct tape.</p>		

Note

Refer to the Workshop Manual for removal and installation of vehicle parts. Not following the procedures for removal/installation in the Workshop Manual could result in an accident or vehicle malfunction.



4. ALUMINUM PEDAL INSTALLATION

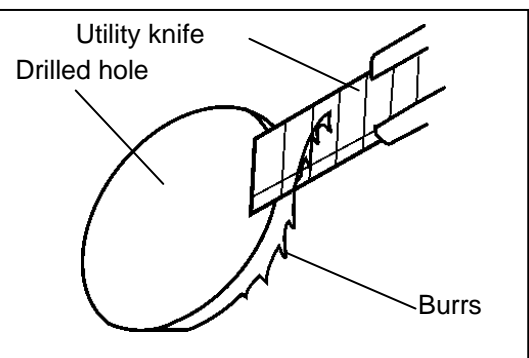
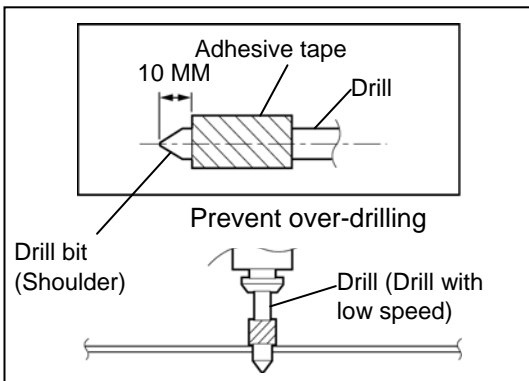
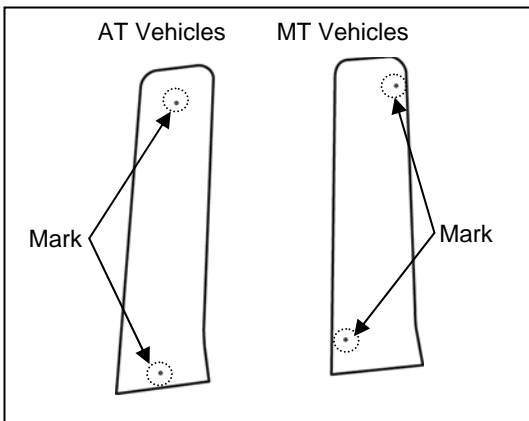
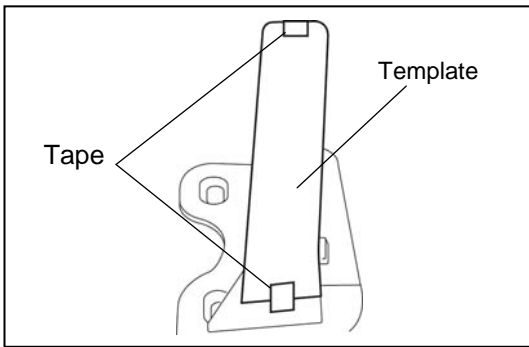

1. Align the template with the outer circumference of the accelerator pedal and attach.

2. Mark the round areas of the template (2 locations)

3. Peel off the template.

4. Wrap the drill bit with duct tape as shown in the figure.

5. Set the drill speed to low.

- Always use a drill with a rotation speed adjustment, otherwise the trunk lid may deform.
- Be careful when handling drills and other sharp objects.
- To prevent scratching and over-drilling, wrap the drill bit with duct tape.

6. With the drill bit pointed perpendicular to the accelerator pedal, drill a hole in the marked position in stages.
Drill hole diameter: From 2.5 mm to 8 mm (1 location).

7. Remove any metal burrs around the drilled hole with a utility knife

- Make sure to remove burrs from the surface so that the surface of the accelerator pedal is smooth.

8. Remove all shavings

- Completely remove drill filings from the cabin, otherwise they may cause abnormal noise.

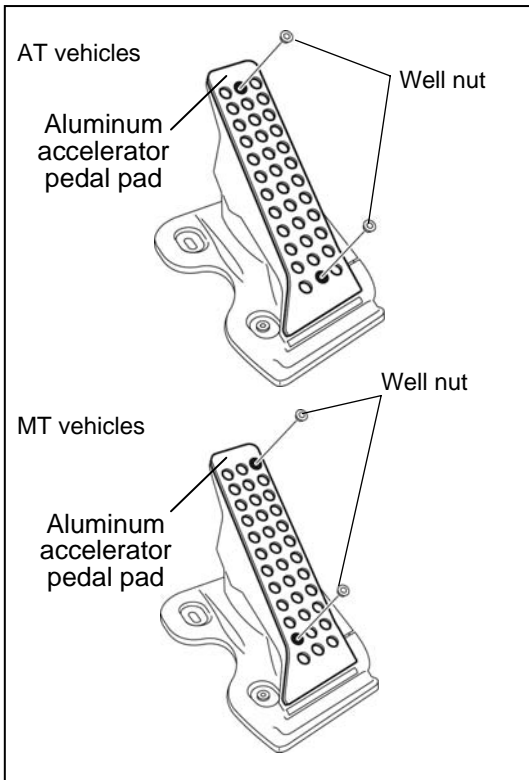

9. Set the aluminum accelerator pedal pad to the accelerator pedal.
10. Install the well nut (2) to the aluminum accelerator pedal pad.

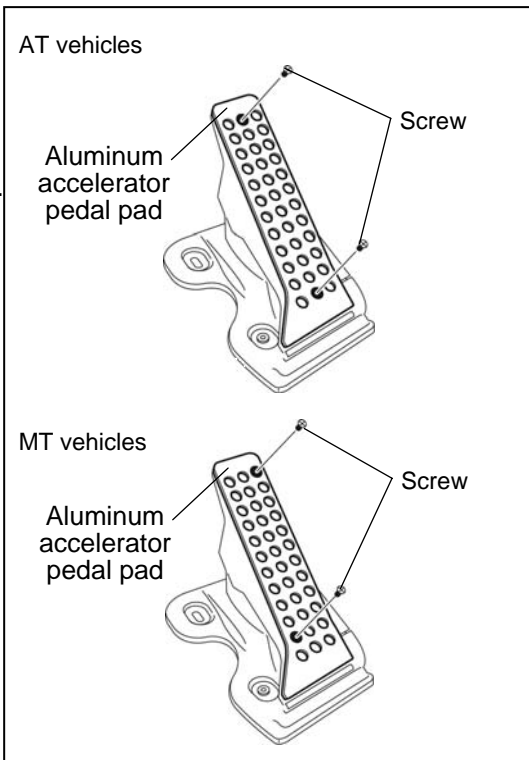

11. Apply a Loctite at the tip of the screw (2).
12. Install the screw (2) to the aluminum accelerator pedal pad.

Screw tightening torque: 0.5-0.7 Nm

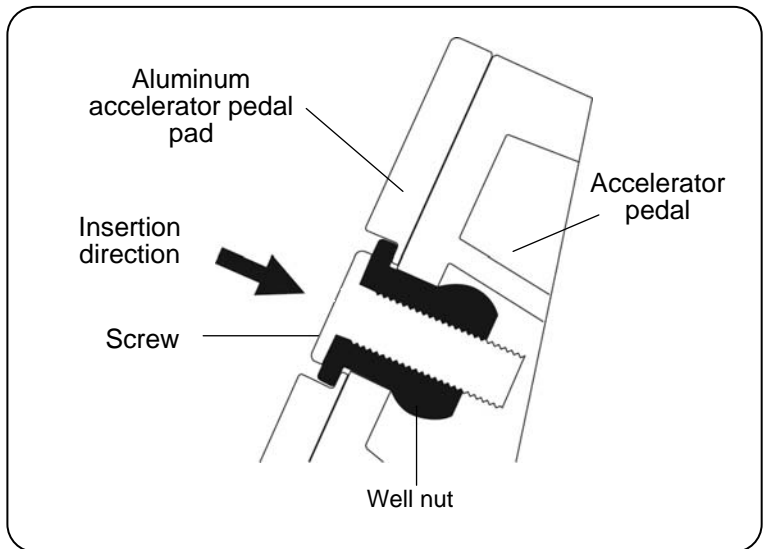

-TO THE CUSTOMER-

- Please check that there are no slack or vibration of screw. Periodical inspection is required.
- Please be careful of the following points for taking care of this product.
 1. Please do not use hard tools, such as brush when you wash this. It may damage the surface.
 2. Please wash the product with water after using thinned neutral detergent, when it is hard to clean off by washing without soap.

Date _____ , _____ , _____				
VIN _____				
Approved		Checked		Person in charge

INSTALLATION INSPECTION SHEET	MAZDA3 MAZDA6 MAZDA CX-5	Aluminum accelerator pedal kit
		BHN1 V9 091 BHN2 V9 091

Perform the following inspections

1. Inspection items after installation

Check

- Verify the fitting between the vehicle part and the installed part, and inspect for damage or dirt.

2. Installation of accessory, operation check

Inspected part	Inspection item	Inspection	Check
Aluminum accelerator pedal	Looseness	Inspect the installation area for looseness.	

The term of validity for this sheet: 3 year